

Telex

User Instructions

CE
FC



Stratus 50-D
Active Noise Reduction Headset

TELEX[®]



Figure 1
Stratus 50-D Reference View

This device complies with part 15 of the FCC Rules, Operation is subject to the following two conditions: (1) This device may not cause harmful interference, and (2) this device must accept any interference received, including interference that may cause undesired operation.



General Description

The Telex Stratus 50-D is a medium-weight, active noise-reduction headset with boom-mounted microphone. It provides up to 25+dB patented digital tonal noise reduction of engine and blade noise, up to 15+dB of analog broadband noise reduction, and 29+dB of passive noise reduction. At 90 Hz the accumulative total is 50+dB of noise reduction.

Design Features (See Figure 1)

Fit and Comfort

The Stratus 50-D incorporates unique features that allow the user to “custom fit” the headset for comfortable operation. Among the features is a headband design that distributes ear cushion pressure evenly over the entire ear with no pressure points. A detented slide adjustment on the headband allows the ear cup to be easily raised or lowered for proper fit. Contributing to the comfort fit is a yoke design that allows the ear cup to pivot in two planes assuring proper performance to the head.

To adjust ear cup pressure, a patented “Comfort Cam™” is rotated to one of three tension settings. The last component in the fit and comfort is the 1” cushion made from heat sensitive slow recovery foam which will conform to your head to provide a perfect seal while spreading the weight over a large area eliminating pressure points.

Boom Microphone

The Stratus 50-D utilizes either an amplified electret noise-canceling microphone to eliminate unwanted cabin noise from entering the communication system. To assure proper operation the microphone must be positioned perpendicular to the mouth close to the lips, slightly off center to the mouth. To facilitate pilot/co-pilot wearing, the boom rotates up to allow the boom to be worn on the left or right side. To minimize windscreen loss, “retaining hooks” are designed into the microphone housing to securely hold the windscreen in place.

Cordage and Plugs

The Stratus 50-D uses shielded cables to protect against RFI (Radio Frequency Interference) and EMF (Electro Magnetic Frequency). Strain relief is added to the cords and plugs to provide protection from wear and tear resulting from normal usage. The headset includes separate receiver and microphone plugs. The receiver plug is set up for stereo usage but a switch on the cordage controls stereo/mono operation.

A separate power cord is provided to allow aircraft power (via cigarette lighter adapter) to plug into the battery module on the headset cord. This will accommodate aircraft power from 8-32 Vdc.

Two cords for connecting cellular telephone and audio devices are included. These cords are standard straight through types. The smaller of the two (2.5 mm connectors) is for connecting cellular telephones. The larger of the two (3.5 mm connectors) is for connecting audio devices

Auto Shut-Off

The Stratus 50-D contains noise-sensing features which measure ambient noise levels. When these ambient noise levels are low for 5 to 7 minutes continuously, the headset automatically shuts off. This feature will prolong battery life and prevent discharge of batteries if the headset is accidentally left on after usage.

Cellphone / audio interface

The Stratus 50-D includes a unique amplified interface allowing for the connection of a cellular telephone and an audio input simultaneously. This setup allows for all of the equipment to be set up before take-off eliminating the need to re-configure cords and equipment when operating the aircraft.

The other unique feature of this interface is the ability to obtain power from the aircrafts communications system. This feature results in increased battery life for the ANR system while keeping the benefits of an amplified interface. By amplifying the inputs, the Stratus 50-D allows the user to adjust volume level at the headset contributing to the ability to not need re-configuring while in flight.

The Telex Stratus 50-D cell phone / audio interface has been designed to function with the widest array of cellular telephones and portable audio devices. There are cell phones and audio devices on the market not designed to industry physical and electrical standards. These devices are not guaranteed to function properly with the Stratus 50-D headset.

Please see the Telex website for additional information and cell phone compatibility lists.

[www.telex.com /aircraft](http://www.telex.com/aircraft)

Microphone Bias Voltage Requirements

The boom microphone operates on a voltage of 8-16 VDC. Output impedance is 50 ohms (Designed for radio input impedances from 50-600 ohms). If you are uncertain whether your avionics equipment meets this requirement, consult the avionics equipment manufacturer.

The cellular telephone / auxiliary audio interface of the Stratus 50-D relies on this same microphone bias voltage for operation. If less voltage / higher impedance is normal in your system, this interface may not operate properly. If unusual or unacceptable performance of the boom microphone or cellular / audio interface is discovered, the cellular /audio interface should be disabled using the accessory mute (described later in this manual.)

Headset Power

The headset will operate with either 4 AA batteries or panel power from 8-32 Vdc.

Panel Power Option

An optional power cord is provided for use in negative ground electrical systems only. Do not attempt to use with positive ground electrical systems. The power cord is designed to connect the battery module to the aircraft power via the cigarette lighter jack.

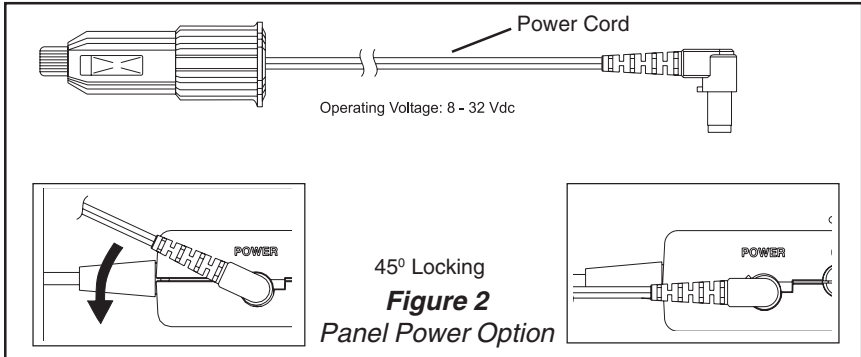

Battery Power

The battery module requires 4 AA Batteries. Alkaline batteries are recommended for best performance. Do not use nickel-cadmium/NiMH rechargeable or lithium batteries.

1. Slide the battery door down in the direction of the arrow, then up to rotate the battery door (Figure 3).
2. Place the batteries into the battery module as shown.
3. Slide the battery door back into place.

Cellular telephone / auxiliary audio input – see above for details

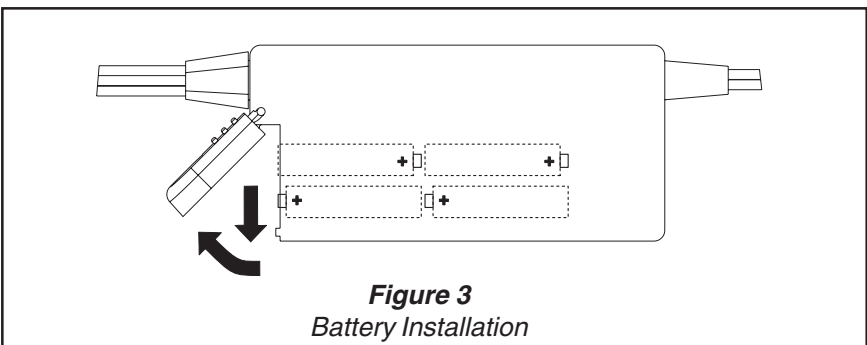

Headset Operation

1. Verify batteries are installed and headset powers on (see previous section.) Connect panel power cord (if not using battery power.)

Headset Operation Cont.

2. Connect the headset as shown in Figure 4. If using the standard version, set the MONO/STEREO headphone switch to match the type of sound system in your aircraft. If the headset is set for stereo and the intercom is set for mono, sound will only come out of one earcup.

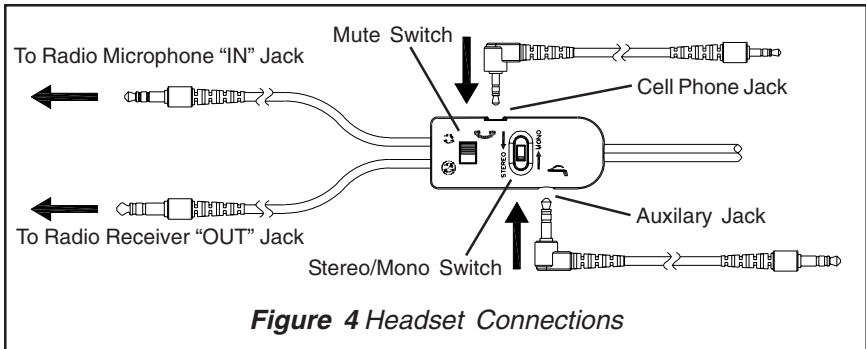

3. Connect cellular telephone and / or audio input devices as desired.
4. Rotate the entire boom overhead to wear the microphone on either the right or left side of the head (See Figure 5).

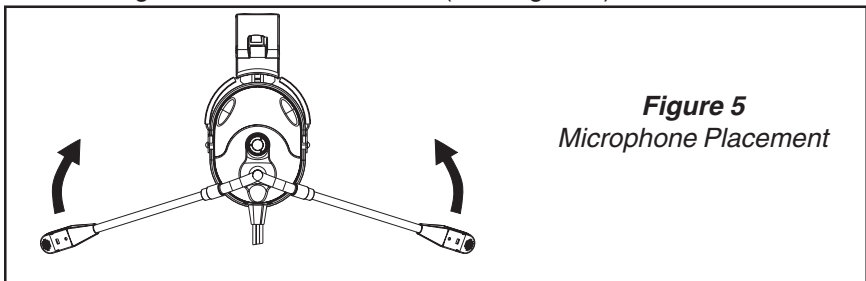

5. Reshape the boom so that the microphone will be in front of the mouth.
6. For best noise cancellation, position the microphone as close to the mouth as possible and speak in a normal voice (Figure 7).
7. **For mic replacement**, press the release catch and carefully pull out the mic element. Avoid pulling the connecting wires (Figure 6).

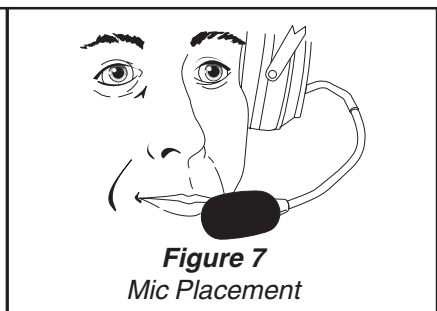
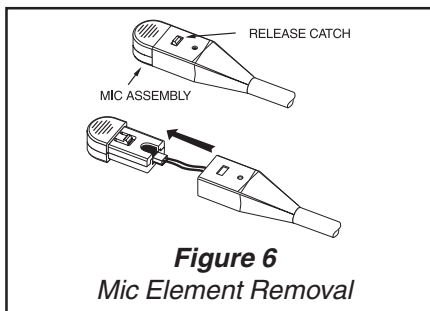

Headset Operation (Cont.)

8. With the headband resting securely on the top of the head, check that the ear cups are centered over the ears. Reposition them if necessary by moving the headband sliders up or down (See Figure 9 on the next page). Proper performance depends on proper fit of the headset as described below.

9. Headband Pressure Adjustments:

There are three pressure settings. Increasing the pressure will improve the seal between the earcup and the head for greater noise reduction. To change the pressure setting, remove the headset and fold the earcup inward as shown in Figure 8, then rotate the Comfort Cam™ to the desired setting. Repeat for both earcups. Both sides of the headband should be set to the same pressure setting to keep the headband properly centered on the head.

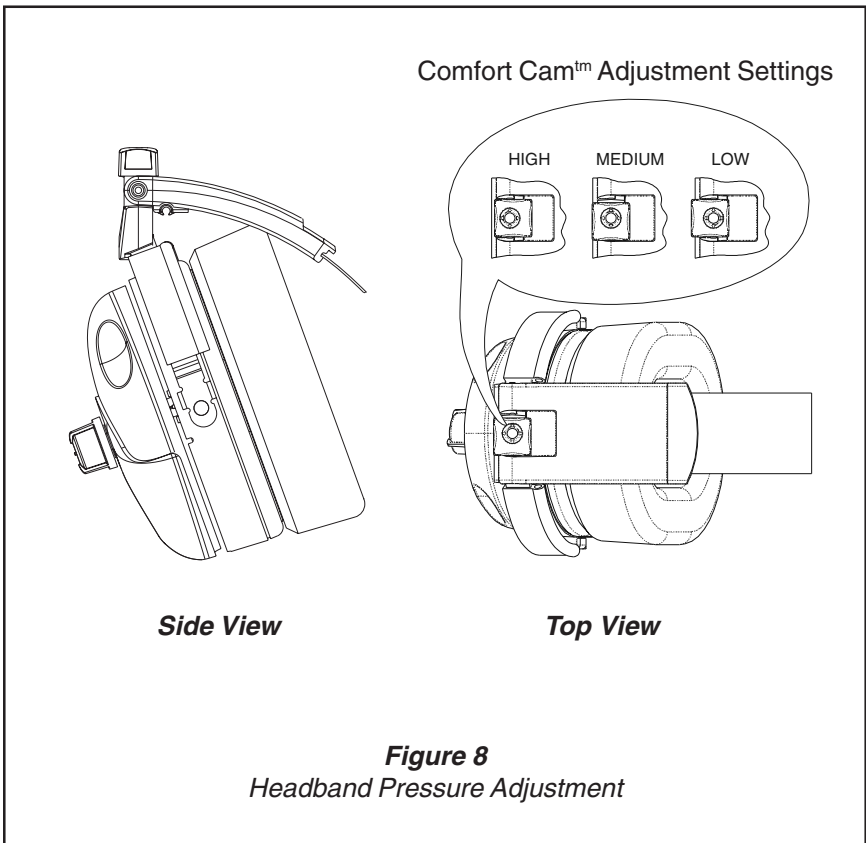

Headset Operation (Cont.)

10. Headband Size Adjustment

To adjust the headband size, move the earcup sliders up or down on the headband (Figure 9). Size is properly adjusted when the earcups are centered over the ears. It is important to adjust both sides of the headband the same to keep the headband and pad properly centered over the head.

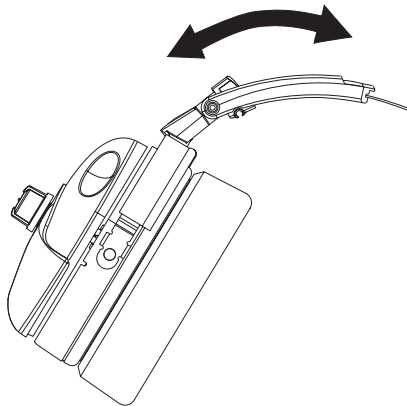

Figure 9
Headband Size Adjustment

11. Volume Adjustment

When the microphone is worn on the left side, volume is increased by rotating the top of the volume controls toward the front of the head. Control operation is reversed when the microphone is worn on the right side (Figure 10).

Volume control affects communications as well as cellphone and auxiliary audio inputs.

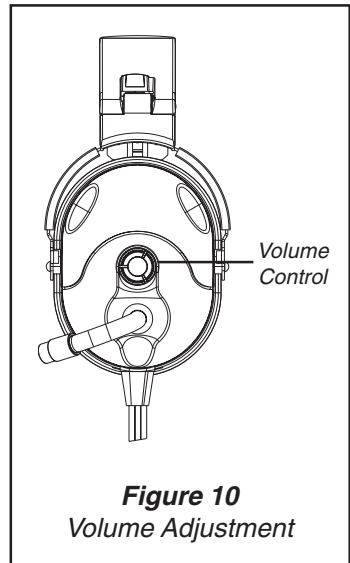

Figure 10
Volume Adjustment

12. Accessory muting

The Stratus 50-D headset is equipped with a switch to quickly and completely disables the cellphone and auxiliary audio devices (Figure 4).

Stratus Controls

Power

Switch the ON/OFF button to turn the Stratus on or off. Green LED indicates power on.

Low Battery

Red LED indicates 20% or less battery life remaining.

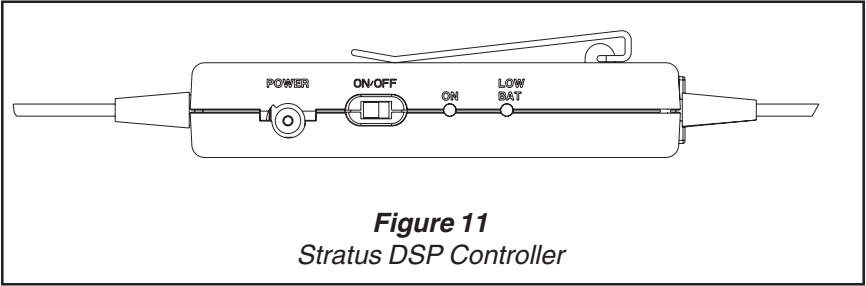

Microphone Gain Adjustment

The microphone gain has been factory-adjusted to the nominal level required for aviation use, and it should normally not require readjustment. Any changes to the mic gain should be done by a qualified avionics technician. To access the gain trimmer, insert a small flat-blade screwdriver through the access hole in the mic assembly. Clockwise rotation of the trimmer increases gain.

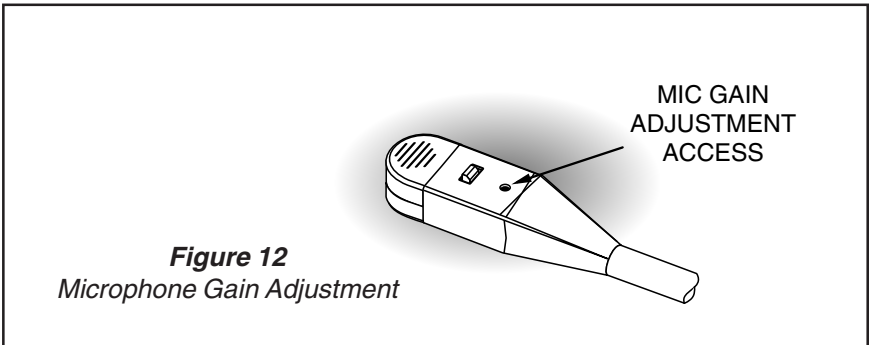

Ear Cushion Replacement

To remove an old ear cushion, simply grasp it and pull it off the earcup. To install a new ear cushion, start at the top of the earcup. Place the flap on the back of the ear cushion over the lip along the top of the earcup. Then, pull the bottom of the ear cushion down over the lip at the bottom of the earcup.

Wiring Diagram

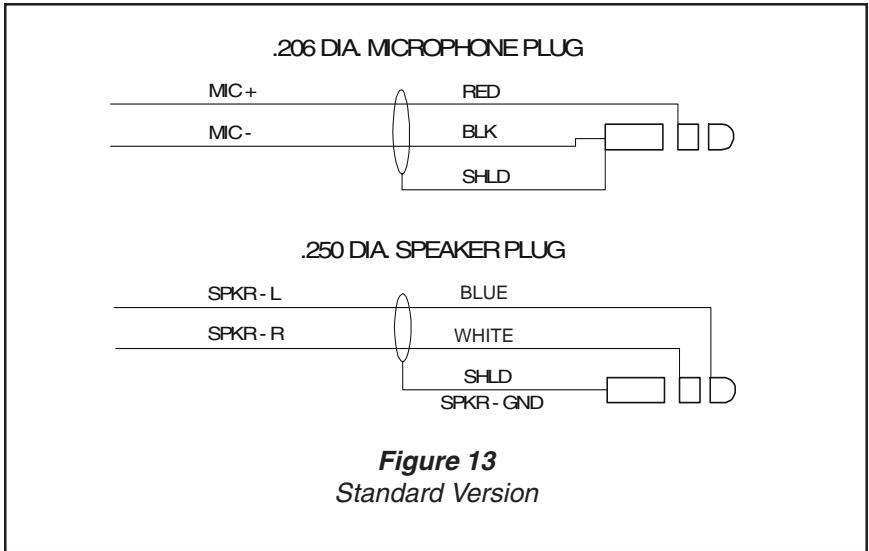

Specifications

Receivers:

Type: Dynamic

Frequency Response: 50 Hz - 10 kHz

Sensitivity: 95 ± 5 dB SPL (1 kHz, 1 mW input)

Impedance (Max. Volume):

Stereo.....300 ohms per side

Monaural.....150 ohms

Headset Power: 4AA Batteries or Panel Power from 8-32 Vdc

Microphone:

Element Type: Amplified noise-canceling electret

Frequency Response: 100 Hz - 3.5 kHz

Sensitivity:

-53 +2/-1 dB (ref: 1V/ μbar at 1 kHz with 12 Vdc supply voltage and 470 ohm DC, 150 ohm AC load)

Matching Impedance:

50-600 ohms

Gain Adjustment Range: ± 5 dB (clockwise rotation increases gain)

Operating Voltage: 8-16 Vdc (supplied by aircraft radio)

Cordage:

Straight Y-cord, 9 ft (2.74 m)

Connectors:

Microphone Plug: PJ-068 or equivalent

Receiver Plug: PJ-055 or equivalent

DC Jack: 2.5mm Dia. Pin +

2.5mm 3 conductor audio jack for connection to cell phone connection

3.5mm 3 conductor audio jack for connection to auxiliary audio

Weight:

Effective Head Weight: Approximately 18.5 oz. (524 g)

Color: Lt. Grey/Purple or

Lt. Grey/Black

Ordering Information

Stratus Headset, with electret mic, battery module, and carrying case (Lt. Grey/Purple)	Catalog no. 301125200
Stratus Headset, with electret mic, battery module, and carrying case (Lt. Grey/Black)	Catalog no. 301125203
Aircraft Power Cord	Catalog no. 550216001
1" Foam-filled ear cushions (package of 2)	Catalog no. 800456015
Headband Pad	Catalog no. 800456017
Replacement electret microphone	Catalog no. 800136100
Microphone windscreen (electret)	Catalog no. 800456000
Clothing Clip	Catalog no. 590637000
Zippered Pouch	Catalog no. 500266000
Cell Phone Accessory Cable	Catalog no. 550216002
Auxillary Device Accessory Cable	Catalog no. 550216003

TELEX COMMUNICATIONS, INC. - LIMITED WARRANTY

Uniform Limited Warranty: Telex branded products are warranted by Telex Communications, Inc. against malfunction due to defects in materials and workmanship for a specified period, as noted in the individual product-line statements below, beginning with the date of original purchase by the end-user. If such malfunction occurs during the specified period, the product will be repaired with new or remanufactured equivalent parts and products or replaced (at our option) without charge. The product will be returned to the customer prepaid.

Exclusions and Limitations: The Limited Warranty does not apply to: (a) exterior finish or appearance; (b) certain specific items described in the individual product-line statements below, (c) malfunction resulting from use or operation of the product other than as specified in the product data sheet or owner's manual; (d) malfunction resulting from misuse or abuse of the product, including accidents; (e) defects resulting from excess moisture, lightning or power surges; or (f) malfunction occurring at any time after repairs have been made to the product by anyone other than a Telex Service Department or any of its authorized service representatives. The Warranty is void if the label bearing the product serial number (if applicable) has been removed or defaced.

Other Express or Implied Warranties Excluded: TO THE EXTENT PERMITTED BY APPLICABLE LAW, THE WARRANTIES SET FORTH HEREIN ARE IN LIEU OF, AND EXCLUSIVE OF, ALL OTHER WARRANTIES, EXPRESS OR IMPLIED. SPECIFICALLY EXCLUDED, WITHOUT LIMITATION, ARE THE WARRANTIES OF MERCHANTABILITY, FITNESS FOR USE OR FOR A PARTICULAR PURPOSE, AND WARRANTIES ARISING FROM COURSE OF DEALING OR USAGE OF TRADE OR ANY OTHER MATTER. IF, UNDER APPLICABLE LAW, IMPLIED WARRANTIES MAY NOT BE VALIDLY EXCLUDED, THE DURATION OF SUCH IMPLIED WARRANTIES IS LIMITED TO THE WARRANTY PERIOD.

Limitation of Remedies; Certain Damages Excluded: REPAIR OR REPLACEMENT OF DEFECTIVE PRODUCTS ARE THE SOLE AND EXCLUSIVE REMEDIES PROVIDED BY TELEX TO THE CUSTOMER OR TO ANY OTHER PERSON AND SHALL CONSTITUTE FULL SATISFACTION OF ALL CLAIMS, WHETHER BASED ON CONTRACT, NEGLIGENCE, STRICT LIABILITY OR OTHERWISE. TELEX'S MAXIMUM LIABILITY SHALL NOT EXCEED THE ACTUAL PURCHASE PRICE PAID FOR THE PRODUCT BY THE CUSTOMER. TELEX AND ITS SUBSIDIARIES SHALL NOT BE LIABLE FOR ANY INDIRECT, INCIDENTAL, PUNITIVE, SPECIAL OR CONSEQUENTIAL DAMAGES INCLUDING, WITHOUT LIMITATION, INJURY TO PERSONS OR PROPERTY OR LOSS OF USE. SOME STATES AND COUNTRIES DO NOT ALLOW THE EXCLUSION OR LIMITATION OF CERTAIN DAMAGES, SO THE ABOVE LIMITATION OR EXCLUSION MAY NOT APPLY TO YOU. IN SUCH STATES AND COUNTRIES, TELEX SHALL BE LIABLE FOR NO MORE THAN THE DIRECT DAMAGES FOR BODILY INJURY AND/OR REAL OR PERSONAL PROPERTY ARISING FROM THE NEGLIGENCE OF TELEX.

Other Rights: This warranty gives you specific legal rights, and you may also have other rights, depending upon where you live.

Obtaining Warranty Service: To obtain warranty service, a customer must deliver the product, prepaid, to the appropriate Telex Service Department listed below or any of its authorized service representatives together with proof of purchase of the product in the form of a bill of sale or invoice.

Applicable Law. The validity, performance and construction of this Limited Warranty shall be governed by the laws of the State of Minnesota without reference to its choice of law principles. The Minnesota federal courts and/or the state courts located in Hennepin County, Minnesota, shall have exclusive personal and subject matter jurisdiction over, and the parties shall each submit to the jurisdiction of such courts and to venue in Minnesota with respect to any dispute concerning the product or pursuant to this Limited Warranty, and all objections to such jurisdiction or to such venue are hereby waived.

For additional warranty repair or service information, contact the Telex service department listed below:

USA, Canada, & Latin America
1720 E 14th Street
Glencoe, MN 55336
Tel: 320-864-3177
Fax: 320-864-3225

CUSTOMER SERVICE

For information or technical assistance, call, write, or email Telex at:

Customer Service Department
 Telex Communications, Inc.
 12000 Portland Ave. So.
 Burnsville, MN 55337 U.S.A.
 (952) 884-4051
 www.telex.com/aircraft

When returning equipment for repair, please enclose an explanation of the problem. And, if the equipment is covered under warranty, please enclose a copy of your proof of purchase. The equipment must be accompanied by documentation stating your name, return address, and telephone number.

Return equipment for factory repair to:

Customer Service Department
 Telex Communications, Inc.
 1720 East 14th St.
 Glencoe, MN 55336 U.S.A.
 (320) 864-3177

Warranty Repairs - If in warranty, no charge will be made for the repairs. Equipment being returned for warranty repair must be sent prepaid and will be returned prepaid.

Non-Warranty Repairs - Equipment that is not under warranty must be sent prepaid to Telex. If requested, an estimate of repair costs will be issued prior to service. Once your approval for repair, and repair of equipment is completed, the equipment will be returned on a collect basis. Collect charges may be avoided by sending a signed check for payment in full along with your signed estimate approval form (the estimate includes the shipping charge).

	Telex Warranty Term Lengths					
	1 Month	3 Months	12 Months	24 Months	36 Months	Other
AVIATION						
Aviation: Headsets					X	
<i>Note: Subject to change without notice.</i>						

Notes



TELEX COMMUNICATIONS, INC. • 12000 Portland Ave. S., Burnsville, MN 55337 U.S.A.